



N64W23760 Main Street  
Sussex, Wisconsin 53089  
Phone (262) 246-5200  
FAX (262) 246-5222  
Email: [info@villagesussex.org](mailto:info@villagesussex.org)  
Website: [www.villagesussex.org](http://www.villagesussex.org)

**AGENDA  
VILLAGE OF SUSSEX  
PARK AND RECREATION BOARD  
7:00 PM TUESDAY, OCTOBER 20, 2020  
SUSSEX CIVIC CENTER – COMMITTEE ROOM 2<sup>nd</sup> FLOOR  
N64W23760 MAIN STREET**

Pursuant to the requirements of Section 19.84, Wis. Stats., notice is hereby given of a meeting of the Village of Sussex Park & Recreation Board, at which a quorum of the Village Board may attend virtually in order to gather information about a subject which they have decision making responsibility. The meeting will be held at the above noted date, time and location. Notice of Village Board Quorum, (Chairperson to announce the following if a quorum of the Village Board is virtually in attendance at the meeting: Please let the minutes reflect that a quorum of the Village Board is present and that the Village Board members may be making comments under any area where the public may comments or if the rules are suspended to allow them to do so.)

1. Roll call
2. Consideration and possible action on the minutes from the August 18, 2020 meeting.
3. Comments from Citizens Present.
4. Discussion and possible action on The Grove playground tower equipment enhancement.
5. Discussion and possible action on The Grove rental policy for blood drive organizations.
6. Park & Recreation Director's Report.
7. Topics for Future Agenda Items.
8. Adjournment

Robert Fourness  
Chairperson

---

Jeremy Smith  
Village Administrator

Please note that, upon reasonable notice, efforts will be made to accommodate the needs of disabled individuals through appropriate aids and services. For additional information or to request this service, contact the Village Clerk at 246-5200.

**VILLAGE OF SUSSEX  
SUSSEX, WISCONSIN**

**Minutes of the Park & Recreation Board meeting held on August 18, 2020.**

Chair Fourness called the meeting to order at 7:00 PM

**1. Roll Call**

Members present: Chair Bob Fourness, Kelly Tetting, Chuck Vojtas, Nadine Coenen, Trustee Ron Wells, Mike Waltz, and Chris Kostka.

Members excused: None

Village Board present: President Anthony LeDonne, Trustee Scott Adkins

Staff present: Parks & Recreation Director, Halie Dobbeck; Assistant Village Administrator, Kelsey McElroy-Anderson

**2. Meeting Minutes**

A motion by Waltz, seconded by Coenen to approve the minutes from the July 21, 2020 meeting as presented. Motion Carried 7-0.

**3. Hidden Hills Tree Preservation Easement N75W23830 Sedge Haven Ct. Lot 18**

Mr. Peter Dickert was present to speak on behalf of his request.

A motion by Fourness, seconded by Waltz to approve the tree removal request as presented. Motion carried 7-0.

**4. Update on The Grove Multisport Courts**

Dobbeck presented the following concerns that have been brought to Board attention and how we have addressed them over the past month.

-Sidewalk approach to parking lot could be blocked if car parked in stall

-We have blocked off the two stalls temporary and will be striping them as no parking areas later this week.

-Bikes are on the courts

-Within the striped stalls we are adding a bike rack to give a home to bikes within the space. This should help with bikes on the courts. We also added a sign to the Pickleball sandwich board not allowing bikes, rollerblades, or skateboards on the court.

-Request for court rules

Rules to be posted at the courts:

Hours: 6:00 a.m. – 11:00 p.m.

Use of courts is on a first-come basis; when others are waiting, please limit play to 60 minutes.

Village-scheduled programs take precedence over drop-in play.

No food, glass, or alcoholic beverages on the courts.

No bicycles, skateboard, roller blades, or pets allowed on the court area.

Do not hang on rim of basketball hoops. Do not sit on Pickleball nets and posts.

Water Fountain and Bathrooms are located on East side of The Grove pavilion.

Please be respectful and courteous to others.

The Village of Sussex is not responsible for lost or stolen articles.

Please help keep this facility clean.

Report any maintenance concerns to 414-587-1965.

In case of emergency, call 911. An emergency phone is located in the vestibule of The Grove pavilion.

-Pickleball Box

We've evaluated the equipment box located off of the courts and there isn't another place to put it at this time. We cannot move it to any other spot that would not impact another court in the same way. The only option might be to put it on a poured pad beyond the courts, however, with a pending decision about fencing, I'd recommend that we hold off pouring any concrete until fencing is considered.

-Fencing

The request for fencing has been added to the budget "extras" list for consideration by the Village Board. The budgetary figure for fencing is roughly \$30,000.

This will include a 10ft fence at the North and South sides of the court and a "swoop" down to a 4ft fence on the East and West sides. The fence would be black vinyl chain link fencing.

**5. Large Park Updates – Budget Recommendations for Village Board Consideration**

Dobbeck presented the following for consideration by the board for funding recommendations for 2021:

Neighborhood Park Update: Prides Crossing

(We currently have roughly \$130,000 in the depreciated playground fund for this project)

Shade Structure for The Grove Splash Pad

Rough cost estimate of \$24,000

Fencing around The Grove MultiSport Courts

Rough cost estimate of \$30,000 (for 10ft fence at N/S, and 4ft fence at E/W)

Board discussion was had regarding the Prides trail system (Fourness), spending less on the neighborhood park than the available amount (Tetting), and when the basketball courts were put in (2005) (Fourness).

A motion by Tetting, seconded by Vojtas to recommend to Village Board to consider: using park improvement funds for Prides Crossing Park, new funding for shade structure(s) for The Grove Splash Pad and new funding for fencing for the MultiSport Courts as large budget items for the 2021 budget.

Motion Carried 7-0.

**6. Village Park Tennis Courts Information**

During the July Park Board meeting, it was requested that information was collected about the Village Park Tennis Courts regarding their condition and possible transformation options.

Dobbeck presented that the tennis courts, fencing and lighting were installed in 1976. The tile system currently on the surface was installed roughly 15 years ago.

An estimate from Armstrong Paving, stated that if the court under the tile system is in good condition, it will require an overlay with an estimated cost of \$50,400. If the court is in poor condition, it will require a strip and repave with an estimated cost of \$59,900. These costs would go towards the restoration of the two tennis courts, or could transform that space into two full-court basketball courts.

Dobbeck shared about the Village Park Master Plan that was last discussed in October of 2018, regarding the courts not staying in this location, but all of that is up to board decision.

Board discussion was had regarding whether tennis courts and basketball courts were in the master plan (LeDonne). Tetting suggested we leave the basketball courts for now to see usage over a longer period

of time and revisit in the future if it remains a problem. Fourness ask the board if there should be any reconsideration for the park budget recommendations motion. Kostka said that it was lowest priority, if even a priority at all as \$60K for 5 years seems like a waste.

### **7. Update on Large Group Gatherings and Recreation Programming**

Dobbeck updated the Board on the following:

- Mask Mandate is being enforced for all those 5 years old and older for all programming.
- Registration opened in our new software Civic Rec, it seemed to have gone smoothly and we have over 700 accounts created since we launched on August 4.
- Online registration opened yesterday. We've kept our same capacities as summer for our programming.
- All classes are around 9 participants and an instructor, with a few exceptions. Outdoor programs like Pickleball remained at higher capacities as they will be playing outside until end of October. Capacities are significantly reduced for accommodating social distancing. We have some instructors that are unwilling to teach in this current environment so some of our regular classes will not be offered in fall due to this.

### **8. Comments from Citizens Present**

Jim Toshner

N58W25740 Fox Hollow Dr.

Sussex, WI 53089

When can we suggest items to add to the extras list? Would like to suggest addition of curtains in Civic Center Multipurpose Room to help with sunlight in the afternoons. Could you use Pickleball registration fees towards items for Pickleball?

Can you get a sponsor for the fence?

(McElroy-Anderson suggested that the group as a collective could bring an amount of money to Village Board to let them know that they'd be willing to contribute a portion of the costs.)

Tim Tyre

6919 N Wildwood Point Rd

Hartland, WI 53029

Sunlight in gym is a safety issue.

What drives recommendations for how money is spent?

(Board responded with professional plans, citizens attending meetings, staff recommendations, and observations)

Roger Ruchti

N59W17815 Prairie Sky Ct

Menomonee Falls, WI 53051

A fence is needed at The Grove because the dew on the grass in the morning creates a slipping hazard. Also cracks in wood floor in the gym need to be addressed.

Marilyn Tyre

6919 N Wildwood Point Rd

Hartland, WI 53029

Appreciates the courts.

When we resurface the multipurpose room floor, she would like something less shiny.

Jeanette Schilter  
N61W23772 Sumac Lane  
Sussex, WI 53089

Can we have snow fence put up around the courts so that no one gets hurt?

(Tetting responded that she had asked staff about that and that it is a safety issue for people going over the fence and the mental fence posts.)

### **9. Park and Recreation Director Report**

Dobbeck updated the Board on the following:

- KidsSports (our contractor for parent child sports and youth sports programming) has decided to end their business. We just learned of this so unfortunately the classes were already published in the activity guide/courier that went out last week. Charlotte is working to determine what Sussex offered programs might look like for Winter/Spring and looking for potential other contractors.
- Don't Touch a Truck was released today. Will be Friday September 11 from 5-7pm, however, it is timed entry with 50 people per slot. This is to keep attendance regulated. Everyone must register for a ticket for the event, they are free, so that they can enter at their desired time slot. We have a total of 350 openings, and already have 145 enrolled, 41%.
- Stonewood Estates Park received its equipment removal and poured in place rim and spot replacement last week.

### **6. Topics for Future Agenda Items**

None

### **7. Adjournment**

A motion by Waltz, seconded by Kostka to adjourn the meeting at 8:19 p.m.

Motion Carried 7-0.

Respectfully Submitted,

Halie Dobbeck  
Parks & Recreation Director



N64W23760 Main Street  
Sussex, Wisconsin 53089  
Phone (262) 246-5200  
FAX (262) 246-5222  
Email: [info@villagesussex.org](mailto:info@villagesussex.org)  
Website: [www.villagesussex.org](http://www.villagesussex.org)

---

## MEMORANDUM

To: Park Board  
From: Halie Dobbeck, Parks and Recreation Director  
Re: Park Board Meeting  
Date: October 20, 2020

---

4. Park Board member Chuck Votjas requested that I look into filling a gap in the climbing structure at The Grove between the tunnel and smaller tower. The playground currently meets all playground safety standards (<https://www.playlsi.com/en/our-story/company/certifications-standards/>); this area of the playground is designed for 5-12 year olds. The playground company has proposed a custom belt design to fill this area per our request. The cost of the custom piece is \$1,156.

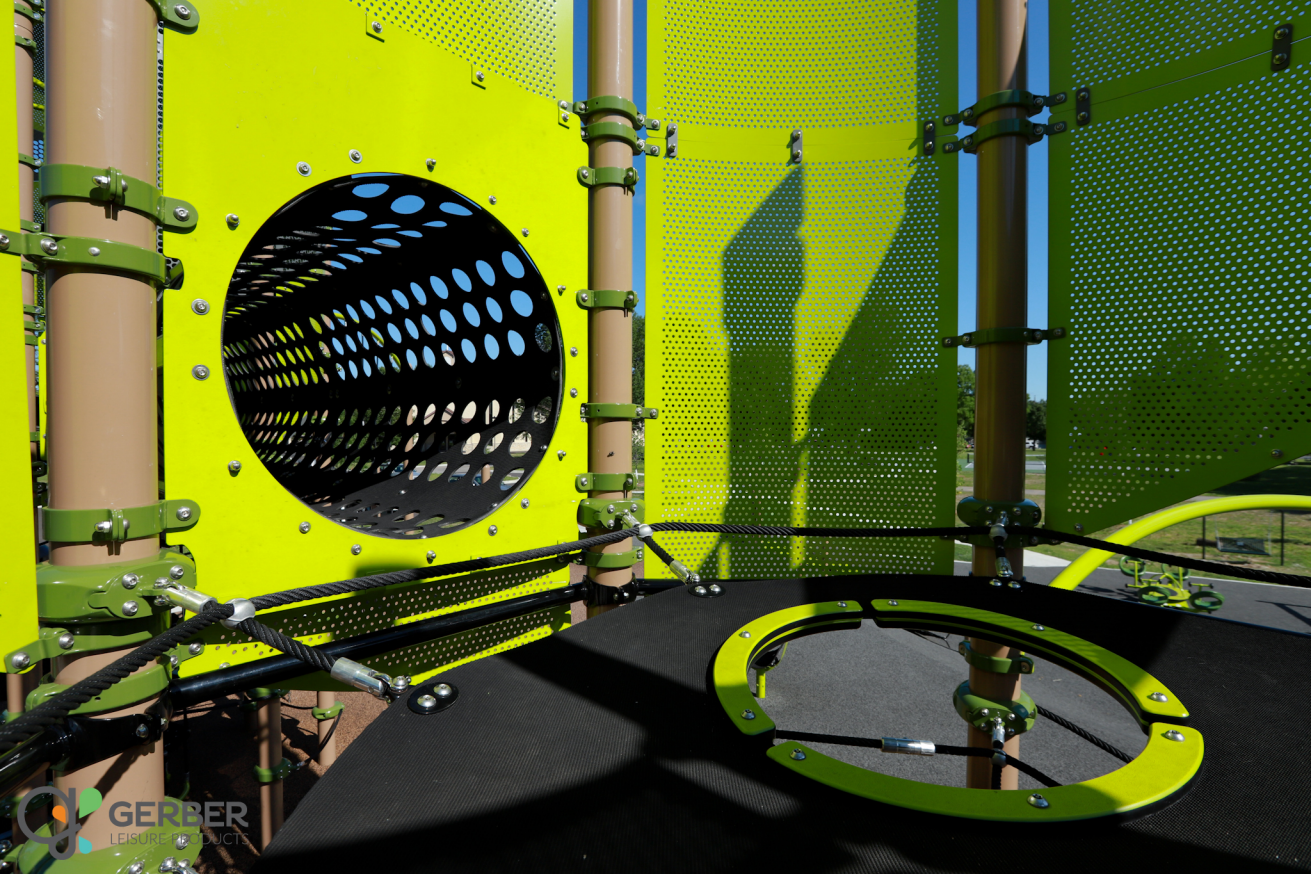



**Gerber Leisure Products, INC.**

PO Box 42  
Mount Horeb, WI 53572  
Phone: 800-236-7758

**QUOTE**

<b>DATE:</b>	9/25/2020
<b>QUOTE Name:</b>	Custom Infill Belting
<b>Valid Until:</b>	12/5/2020

Prepared by: Meghan Barrett / meghan@gerberleisure.com

Customer
Village of Sussex- Village Park Attn: Halie Dobbeck  hdobbeck@villagesussex.org

DESCRIPTION	QTY	PRICE	AMOUNT
CP013969: Disc net infill belt from mat to Belt Tunnel panel.	1	920	920.00
Freight to Installer	1	236	236.00
Professional installation on Gerber	1	0	0.00

**TERMS AND CONDITIONS**

1. A 50% deposit is required to place the order
  2. Customer will be billed for equipment upon receipt of signed quote
  3. Additional services will be billed upon completion of the project
  4. Payment will be due within 30 days of invoice date
  5. Please mail or email signed price quote to the address above
- Customer Acceptance (sign below):*

Subtotal	\$1,156.00
Taxable	\$0.00
Tax rate	0.000%
Tax due	\$0.00
Other	\$0.00
<b>TOTAL Due</b>	<b>\$1,156.00</b>

x \_\_\_\_\_  
Print Name:

If you have any questions about this price quote, please contact: Meghan Barrett at 608-514-6323 / meghan@gerberleisure.com

***Thank You For Your Business!***



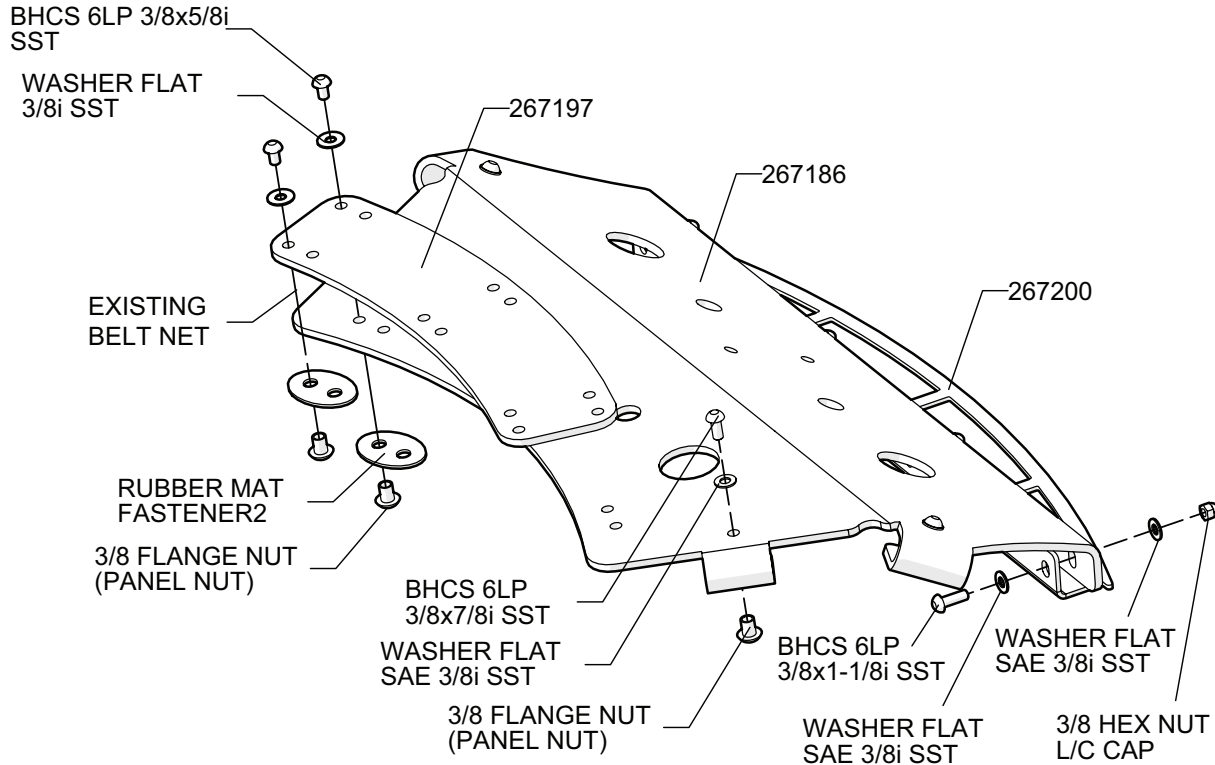

## Parts List

PART NUMBER	DESCRIPTION	QTY.
267200	CUST INFILL TNL SPT FLANGE PNT	1
267197	CUST INFILL OVERLAP BELT	1
267186	CUST INFILL 254627 BELT	1
193985	RUBBER MAT FASTENER2	6
100365	WASHER FLAT SAE 3/8i SST	12
100362	WASHER FLAT 3/8i SST	12

PART NUMBER	DESCRIPTION	QTY.
100353	FLG NUT 6LP 3/8-16 SST	16
100349	3/8 HEX NUT L/C CAP	4
100198	BHCS 6LP 3/8x1-1/8i SST	4
100196	BHCS 6LP 3/8x7/8i SST	4
100195	BHCS 6LP 3/8x5/8i SST	12

## Installation Instructions

- 1) Bolt the two belts together with the rubber mat fasteners on the bottom.
- 2) Line up the support flange below crawl tunnel entrance and use new hardware to bolt belt between the tunnel panel and the infill panel.
- 3) Wrap side loops around the existing ropes, and attach hardware loosely, so slack is left to line up to the disc net.
- 4) Lay belting over the top of the existing disc belt and transfer drill six 0.5" holes through the belt material.

- 5) Attach with new hardware to the disc net with rubber mat fasteners below.
- 6) Snug the belt and tighten bolt on the tunnel panel, then tighten bolts on loops around the ropes.

## Additional Information

Approx. Weight: 29 lbs.

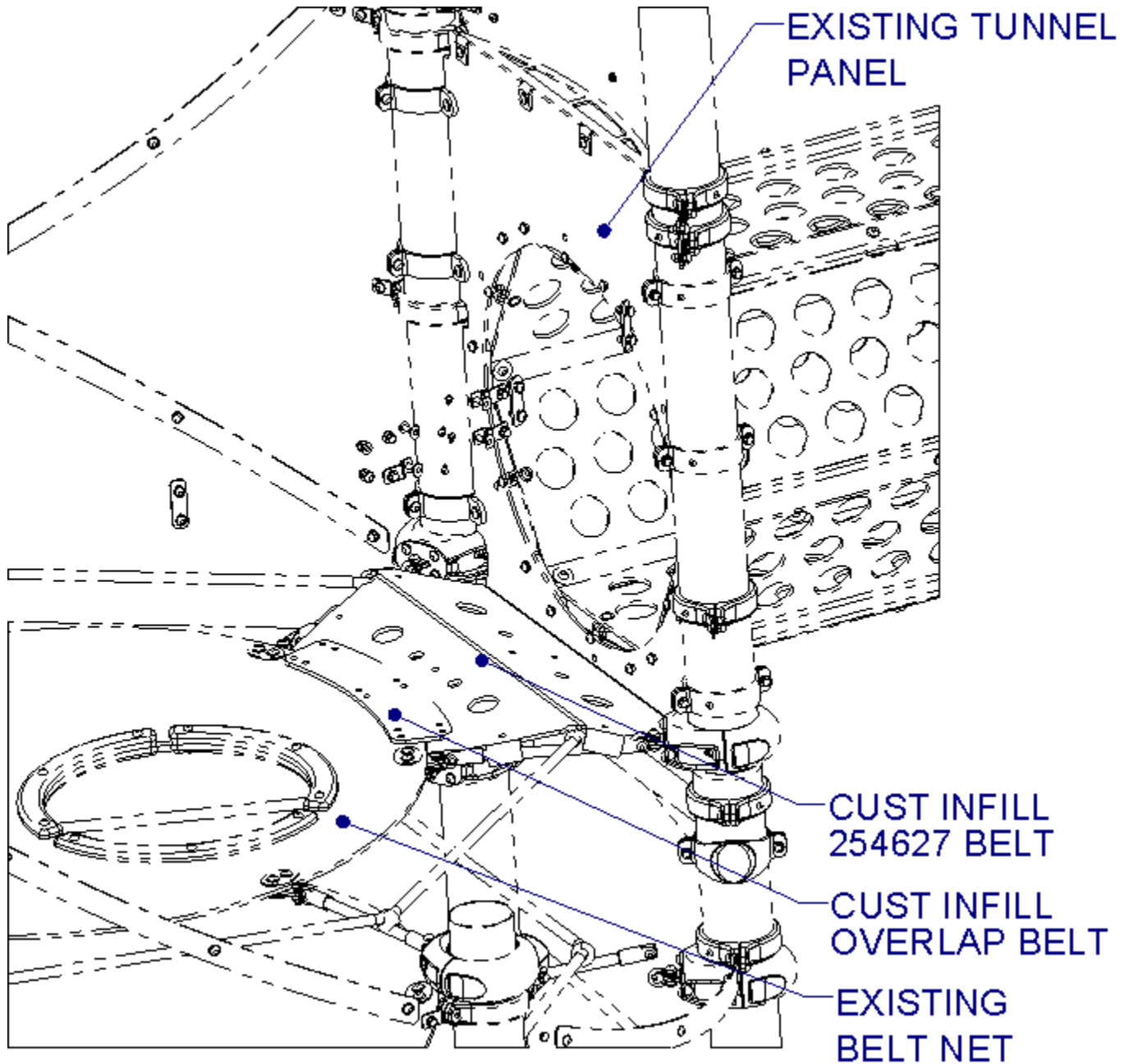



N64W23760 Main Street  
Sussex, Wisconsin 53089  
Phone (262) 246-5200  
FAX (262) 246-5222  
Email: [info@villagesussex.org](mailto:info@villagesussex.org)  
Website: [www.villagesussex.org](http://www.villagesussex.org)

---

## MEMORANDUM

To: Village Board  
From: Sam Liebert, Administrative Services Director  
Re: The Grove Rental Policy in regards to Blood Banks  
Date: October 12, 2020

---

On October 5<sup>th</sup>, I spoke with Natalie Kukla of the Versiti Blood Center of Wisconsin about their plans to continue working with the Village of Sussex in 2021. Versiti has been a longtime partner with the Village and Lioness Club. Under this partnership, the Lioness Club (as a non-profit entity) would 'host' Versiti at the Civic Center and help them with their blood drives.

It is staff's understanding, that the Lioness Club has recently disbanded and is no longer incorporated. Per a past agreement with the Village and the Lioness Club, six (6) dates a year were given to Versiti to rent space (free of charge) at the Civic Center.

Versiti would like to continue partnering with the Village to run their blood drives at The Grove at Village Park. Due to COVID-19, new standards are required to space beds and staff apart – and they believe that The Grove fits their needs. We've worked with them a couple times this year with having their latest blood drives at The Grove, and the layout and space seem to accommodate their mission well. For 2021, Versiti would like to expand their blood drives to once per month.

On October 5<sup>th</sup>, I also received an email from Jenelle Blavat with the American Red Cross. Again, due to COVID-19 restrictions and guidelines, they are searching for larger spaces that would accommodate blood drives. The American Red Cross would like to use The Grove as well for their blood drives, also at a free or discounted rate. The American Red Cross would also like to utilize The Grove once per month in 2021.

There are some scheduling concerns. For the months of May, June, July and August the Village has day camp programmed for use at The Grove. For these four (4) months, any sort of blood drive would need to be scheduled somewhere else. The Civic Center would be made available (Community Room, Board Room or Gym).

#### Other Communities:

- Hartland – Works with 2-3 groups on a regular basis. No charge for the rental of space. Allows a maximum of one (1) blood drive per month.
- Pewaukee – Work with both American Red Cross and Versiti. No charge for rental of space. Each organization gets two (2) rentals per year, effectively there is one blood drive per quarter.
- Menomonee Falls – No response.

With the Lioness Club now disbanded and two competing groups, with the same civic minded missions, looking to utilize The Grove – staff is looking for direction on how to proceed into 2021. Staff has reached out to the Lion's Club, but has yet to hear back.

Staff would like the following questions answered:

1. Do we offer blood drive organizations a free or discounted rental rate for use at The Grove? Any recommendation to do so would need to be recommended to the village board.
2. If we do work with the groups, how do we fairly and equitably offer usage to both organizations?
3. Do we limit to one blood drive per month?



N64W23760 Main Street  
Sussex, Wisconsin 53089  
Phone (262) 246-5200  
FAX (262) 246-5222  
Email: [info@villagesussex.org](mailto:info@villagesussex.org)  
Website: [www.villagesussex.org](http://www.villagesussex.org)

---

## MEMORANDUM

To: Village Board  
From: Sam Liebert, Administrative Services Director  
Re: The Grove Rental Policy in regards to Blood Banks  
Date: October 12, 2020

---

On October 5<sup>th</sup>, I spoke with Natalie Kukla of the Versiti Blood Center of Wisconsin about their plans to continue working with the Village of Sussex in 2021. Versiti has been a longtime partner with the Village and Lioness Club. Under this partnership, the Lioness Club (as a non-profit entity) would 'host' Versiti at the Civic Center and help them with their blood drives.

It is staff's understanding, that the Lioness Club has recently disbanded and is no longer incorporated. Per a past agreement with the Village and the Lioness Club, six (6) dates a year were given to Versiti to rent space (free of charge) at the Civic Center.

Versiti would like to continue partnering with the Village to run their blood drives at The Grove at Village Park. Due to COVID-19, new standards are required to space beds and staff apart – and they believe that The Grove fits their needs. We've worked with them a couple times this year with having their latest blood drives at The Grove, and the layout and space seem to accommodate their mission well. For 2021, Versiti would like to expand their blood drives to once per month.

On October 5<sup>th</sup>, I also received an email from Jenelle Blavat with the American Red Cross. Again, due to COVID-19 restrictions and guidelines, they are searching for larger spaces that would accommodate blood drives. The American Red Cross would like to use The Grove as well for their blood drives, also at a free or discounted rate. The American Red Cross would also like to utilize The Grove once per month in 2021.

There are some scheduling concerns. For the months of May, June, July and August the Village has day camp programmed for use at The Grove. For these four (4) months, any sort of blood drive would need to be scheduled somewhere else. The Civic Center would be made available (Community Room, Board Room or Gym).

Other Communities:

- Hartland – Works with 2-3 groups on a regular basis. No charge for the rental of space. Allows a maximum of one (1) blood drive per month.
- Pewaukee – Work with both American Red Cross and Versiti. No charge for rental of space. Each organization gets two (2) rentals per year, effectively there is one blood drive per quarter.
- Menomonee Falls – No response.

With the Lioness Club now disbanded and two competing groups, with the same civic minded missions, looking to utilize The Grove – staff is looking for direction on how to proceed into 2021. Staff has reached out to the Lion's Club, but has yet to hear back.

Staff would like the following questions answered:

1. Do we offer blood drive organizations a free or discounted rental rate for use at The Grove? Any recommendation to do so would need to be recommended to the village board.
2. If we do work with the groups, how do we fairly and equitably offer usage to both organizations?
3. Do we limit to one blood drive per month?